

Technical Data Sheet

Lowicryl K4M/K11M and LOWICRYL HM20/HM23

#14330-14360

1. Introduction:

Lowicryl K4M and HM20 are highly cross linked acrylate-and methacrylate-based embedding media which have been designed for use over a wide range of embedding conditions (3,8,14). These resins have been formulated to provide low viscosity at low temperatures: K4M is usable to -35°C, and HM20 to -70 degrees C. The investigator also has a choice of either a polar (hydrophilic; K4M) or a non polar (hydrophobic; HM20) embedding medium (8).

Both resins are photopolymerized by long wavelength (360nm) ultraviolet light. Since the initiation of the polymerization is largely independent of temperature, blocks may be polymerized at the same temperatures which are used for infiltration. The resins may also be chemically polymerized at +60°C.

The hydrophilic properties of K4M provide two distinct advantages. During dehydration and infiltration the specimens may be kept in partially hydrated state, since K4M may be polymerized with up to 5% (by weight) water in the block (8,14). Secondly, K4M is particularly useful for immunolabeling of sections using specific antisera or lectins (see section 8). The use of K4M results in a better structural preservation (21), an improved preservation of antigenicity (7,20,22) and a significantly lower background labeling.

K4M and HM20 have also been used to produce high contrast images of completely unstained thin sections in the scanning transmission electron microscope by Z-contrast(10).

K4M and HM20 are usable at room temperature as well as low temperatures; the applications of the resins are left to the discretion of the investigator. This booklet mainly addressed the techniques of low temperature embedding, solutions to the most common problems which are encountered in low temperature work, and general suggestions for the use of K4M and HM20.

Lowicryl K11M and HM23 have similar properties K4M and HM20 but can be applied at 20°C to 30°C lower temperature. K11M has in addition a much lower viscosity compared with K4M.

The two resins have been designed to explore freeze substitution combined with low temperature embedding (below -50°C). They can obviously also be used in the same way as K4M and K11M (2,9).

2. Fixation:

Any of the standard aldehyde fixation procedures (perfusion, immersion or combinations there of) may be used. Since the resins are in most cases photopolymerized, the use of fixatives which also have staining properties (e.g. osmium tetroxide) is not generally recommended. An excessive staining of the material will interfere with the penetration of UV light into the center of the specimen, resulting in a incomplete polymerization (1,3,8). Excess osmium tetroxide in the specimen will also attack the unsaturated bonds in the resin.

Naturally occurring pigments, if present in usual amounts, generally do not interfere with the polymerization of the Lowicryl resins. Some samples which are heavily pigmented and absorb strongly at 360 nm may produce blocks of less than optimal quality (1).

To insure the adequate penetration of UV light and an even polymerization, individual samples should be <0,5mm³. Tissues, cell pellets, etc. May be minced either in the later stages of fixation or in the buffer wash immediately following fixation.

3. Dehydration at Low Temperatures:

The majority of low temperature embedding procedures are performed in one of two ways: (1) gradually decreasing the temperature during dehydration, as the material is exposed to an ascending series of concentrations of the dehydrating agent, or (2) freeze-substitution. For most routine applications, the first method is recommended.

3.1 The Progressive Lowering of Temperature (PLT) Technique:

This procedure involves stepwise reductions in temperature as the concentration of dehydration agent is increased (3,8,14). A temperature is selected at each step which is above the freezing point of the concentration used in the step just before; this is indeed the concentration of the dehydration agent contained in the tissue block, when introduced into the next higher concentration of the dehydrated series. For the freezing points of various dehydrating agents, consult graph 1.

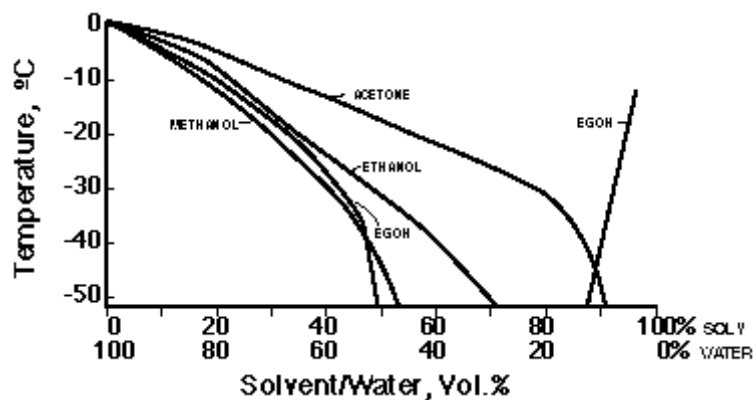

Graph 1: Freezing points of commonly used dehydrating agents (solvents) as a function of concentration. EGOH + Ethylene glycol. Note the rise in the freezing point of EGOH at higher concentrations.

DURING DEHYDRATION AND FILTRATION, THE SAMPLES SHOULD BE PERIODICALLY AGITATE EITHER BY STIRRING WITH A TOOTHPICK OR BY GENTLY SWIRLING THE SAMPLE VIALS.

Most polar and nonpolar dehydrating agents may be used with both resins. Due to its hydrophobic nature, however, HM20 is immiscible with ethylene glycol and dimethylformamide. Both resins are freely miscible with methanol and ethanol.

A representative dehydration schedule for ethanol is given as follows:

Ethanol	Temperature (degrees C)				Time
Vol. %	K4M	HM20	K11M	HM23	min.
30	0°C	0°C	0°C	0°C	30
50	-20°C	-20°C	-20°C	-20°C	60
70	-35°C	-50°C	-50°C	-50°C	60
95	-35°C	-50°C	-60°C	-60°C	60
100	-35°C	-50°C	-60°C	-80°C	60
100	-35°C	-50°C	-60°C	-80°C	60

The times and temperatures above the minimum values and have to be adjusted accordingly to the type of specimen and its size. Schedules for other solvents can be developed provided that their freezing points are considered. (See graph 1).

3.2 Achieving Low Temperature:

There are several methods to achieve the low temperatures for dehydration, infiltration and polymerization (11):

1. Balzers Low Temperature Embedding (LTE) Apparatus. Provides four sample holding blocks, which may be preset to any temperature from 0 degrees C to -50°C. Also contains a stirring head for continuous sample agitation. Information on this apparatus is available from Balzers Corp.
2. For -20°C, use ice: NaCl, 3:1 (wt:wt). Monitor the temperature carefully, as this mixture requires periodic replenishment. The lifetime of the mixture may be lengthened by keeping it in a glass lined dewar, and by placing the dewar in a refrigerator or a cold box.

To minimize temperature gradients, it is preferable to use an aluminum block with drilled holes which will accommodate the sample vials. The metal block is first placed in the cooling bath and allowed to equilibrate before the sample vials are placed in the block.

3. For temperatures of -35°C to -40°C , a household chest-type freezer may be used.
4. For lower temperatures (i.e., -30°C to -70°C) use either a low temperature chest-type freezer or mixtures of o- and m-xylene in combination with crushed dry ice¹.

For xylene mixtures, refer to Graph 2. The temperature is determined by the volume ratios of o- to m-xylene. Crushed dry ice is added to the xylene mixtures to form a thick slurry. When mixed in a dewar flask, these xylene-dry ice mixtures will maintain a constant temperature for ca. 8-10 hours.

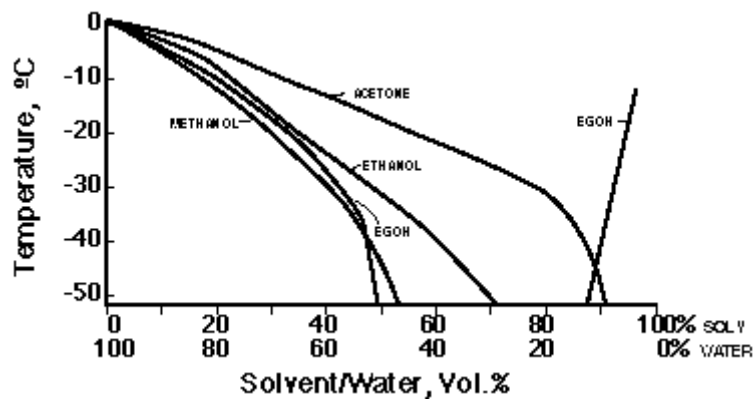

Graph 2: Temperatures of crushed dry ice-xylene slurries, as a function of the ratio of o- to m-xylene.

XYLENE VAPORS ARE TOXIC. WORK WITH XYLENE COOLING BATHS ONLY IN A WELL-VENTILATED FUME HOOD.

3.3 Freeze-Substitution:

The Lowicryl resins have been successfully used with freeze-substitution methods. The primary advantage of these techniques is that the infiltration and polymerization temperatures need to be raised above -35°C .

These techniques require special apparatus, since a high initial rate of cooling is critical for such procedures. For details on instrumentation contact the following firms or their distributors:

1. Propane Jet Freezer: Balzers Corporation
2. Cryoblock Liquid Helium Freezer: Reichert-Jung.

For details on the techniques involved, consult references (12) and (17).

4. Preparation of Resins and Infiltration:

METHACRYLATES, SIMILAR TO OTHER EMBEDDING MEDIA, MAY CAUSE ECZEMA ON SENSITIVE INDIVIDUALS.

ALWAYS USE GLOVES FOR ALL STEPS INVOLVING USE OF THE RESINS. IN CASE OF CONTACT WITH SKIN, WASH THOROUGHLY WITH SOAP AND WATER. SUITABLE GLOVES WITH GOOD PROOFNESS TO ACRYLATES ARE THE "KIMGUARD VINYL GLOVES" OF KIMBERLY-CLARK.

4.1 Mixing Instructions:

Due to their very low viscosities, the Lowicryls do not require vigorous stirring to mix the resin components. Mixing too vigorously or for prolonged periods may result in the incorporation of oxygen into the resin, thereby interfering with the polymerization. This is especially important if a thermal polymerization (+60°C) is used.

Avoid inhaling the vapors from the resins. Use a well-ventilated fume hood for mixing the Lowicryls.

1. Weigh out, into a tared vial, the crosslinker and the monomer. Mix gently by one of the following methods for three to five minutes:
 - a) Bubble a continuous stream of dry nitrogen gas into the mixture with a Pasteur pipette. The nitrogen stream will mix the resin, and at the same time it will prevent the incorporation of oxygen.
 - b) Mix gently with a glass rod.
 - c) If the vial has a snap-cap or lid, slowly rock the covered vial from side to side, avoiding the formation of air bubbles or foaming.
2. Add the initiator, and continue mixing until the initiator is completely dissolved in the resin.

4.2 Mixtures for Ultraviolet Polymerization:

K4M			HM20	
Crosslinker A	2.70 gm		Crosslinker D	2.98 gm
Monomer B	17.30 gm		Monomer E	17.02 gm
Initiator C* 0.	0.10 gm		Initiator C*	0.10 gm
K11M			HM23	
Crosslinker HM20	1.0 g		Crosslinker F	1.1 g
Monomer I	19.0 g		Monomer G above -50 °C	18.9 g
Initiator C	0.1 g		Initiator C -50°C to -70°C	0.1 g

			Initiator J below -70°C	0.1 g
			Initiator J	0.15 g

*For polymerization from -50°C to 0°C. Above 0 degrees C, the initiator C should be replaced by the same amount of benzoin ethylether.

The above mixtures will produce blocks of average hardness. The hardness may be varied by incorporating more or less crosslinker to resin mixture (more crosslinker produce harder blocks).

For HM20 , the crosslinker concentration may be varied from 5 to 17 weight % (1.0 to 3.4 gm/20 gm resin).

For K4M, the crosslinker concentration may be varied from 4 to 18 weight % (.08 to 3.6 gm/20 gm resin).

4.3 Mixture for Thermal (Chemical) Polymerization of HM20 and K4M at +60 °C

Although the resins are primarily designed for UV polymerization, it is also possible to polymerize them with a more classical thermal (+60 degrees C) technique.

For such a procedure, mix a crosslinker and monomer as previously mentioned (Section 4.1). nitrogen bubbling is the method of choice.

Instead of initiator C, substitute the following amounts of dibenzoyl peroxide:

1. HM20: 0.5% (by weight) dibenzoyl peroxide
2. K4M : 0.3% (by weight) dibenzoyl peroxide

Dibenzoyl peroxide is generally supplied as a paste with dibutylphthalate or a powder moistened with water. Compensate for the added ingredients, so that the resin receive the above amounts of peroxide, exclusive of the additives.

4.4 Infiltration at Low Temperatures:

Infiltration with Lowicryl resins at low temperatures is similar to room temperature infiltration with other embedding media. The exact protocol will depend upon the temperatures and dehydrating agent chosen, and the viscosity's of the dehydrating agent and of the resin at those temperatures.

Typical infiltration schedule with ethanol, is given below.

RESIN:ETHANOL	TIME	MINIMAL TEMPERATURES
----------------------	-------------	-----------------------------

vol. : vol.	time	K4M	HM20	K11M	HM23
1:1	60 min.	Very	-50°C	-60°C	-80°C
2:1	60 min.	viscous	-50°C	-60°C	-80°C
pure resin	60 min.	below	-50°C	-60°C	-80°C
pure resin	overnight or 4-16 hrs.	-40°C	-50°C	-60°C	-80 °C

It is important to keep the samples in movement during infiltration in order to facilitate equilibration of the tissue interior with the bulk of the infiltration liquid.

5. Polymerization:

5.1 Ultraviolet Polymerization at low temperature

The Polymerization Chamber : Samples may be polymerized in either BEEM® or gelatin capsules. A suitable capsule holder is required so that the capsules receive UV irradiation from all sides. A stand (fig.1) is constructed from heavy gauge wire, and finer gauge twisted wire loops are soldered onto the stand to hold the capsules.

The size of the capsules is important, large volumes, over 1ml, can easily lead to a temperature increase during polymerization. The heat produced by the exothermic polymerization reaction is not dispatched to the surrounding. The same happens when the samples are polymerized too fast (for further details see ref.4).

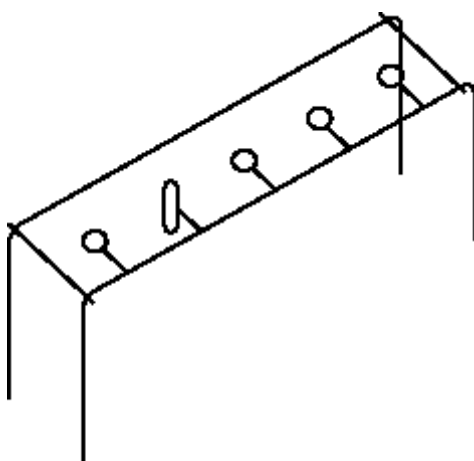

Fig. 1. A wire capsule holder for UV polymerization.

The light source must be 360 nm long-wave length UV, preferably two 15-watt fluorescent tubes, similar to those used for thin layer chromatography ².

² Philips TLD 15W or similar fluorescent tube.

A polymerization chamber (Fig. 2) can be constructed which will fit in a deep chest-type freezer or in a cold room. To provide diffuse illumination, a right-angle reflector is suspended below the UV lamps. All six inner surfaces as well as the reflector, should be lined with aluminum foil. The capsule holder is placed 30 - 40 cm below the fluorescent lamps. The entire box should be too tightly constructed; ventilation from the top and bottom will provide air circulation and will minimize temperature gradients in the chamber.

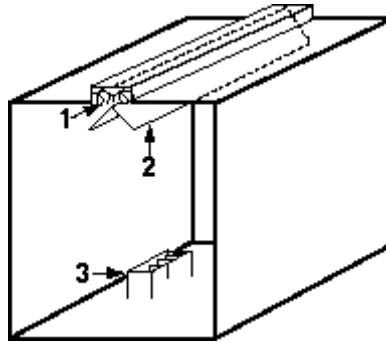

Fig 2. A polymerization chamber for indirect UV irradiation, the UV source (1) is diffused by a right-angle reflector (2). The capsule holder (3) is place 30-40 cm below the UV source. See section 5.1

A small, hand held UV lamp may also be used, provided it emits at 360 nm. Some of the small "mineral lamps" have both a long - and short-wave UV source. In such a case, mask the dimensions of the polymerization chamber, and reduce the lamp-to-capsule distance to ca. 10-15 cm. Irradiation from the bottom of the chamber will reduce the attenuation of the UV light by the resin. This is recommended for low-intensity UV sources.

In either the large or the small polymerization chamber, make a trial run by polymerizing pure resin in capsules. Shrinkage and deformation along the sides of the block indicate that the polymerization is too rapid.

In such a case increase the distance between the lamps and the capsules.

5.2 Ultraviolet Polymerization at Low Temperatures: Protocol:

1. Fill capsules with fresh pre-cooled resin. The capsules should be fill to the top, to minimize dead air space over the resin.
2. Transfer samples to the capsules with Pasteur pipettes; close the capsules, and allow them to equilibrate at the chosen temperature for 10-15 minutes. To minimize the condensation of water and the crystallization of ice on the sample vials and capsules, all apparatus should be precooled, and steps 1 and 2 should be performed in the cold.

3. Polymerize K4M and HM20 for at least 24 hours under UV-light, at -30 °C to -40°C (the lowest recommended temperature for polymerization is -50°C).

Polymerize K11M and HM23 for at least 5 days at not lower temperature than -60°C and -80°C respectively. At these low temperatures it can be difficult to keep the UV- lamps burning with sufficient yield of irradiation. This leads to a much longer polymerization time.

4. Remove the capsules from the cold, and continue "curing" under UV for 2-3 days at room temperature.

5.3 Chemical Polymerization of K4M and HM20 at +60°C:

1. Place fresh resin (see Section 4.3) in gelatin capsules; transfer samples to capsules, and fill capsules approximately 3/4 full.
2. Close capsules and polymerize at +60°C for 2-3 days. The use of gelatin capsules is recommended for chemical polymerization at +60 °C. The plasticizer in BEEM® capsule may interfere with polymerization at the periphery of the blocks.
3. The chemical polymerization of K4M and HM20 with peroxides is an exothermic reaction. To prevent an uncontrolled rise in temperature. The capsules should be in contact with a heat sink. Use an aluminum block with predrilled holes which will accommodate the capsules (6). The capsules should fit firmly in the holes.

6. Sectioning:

For best results, trim the final pyramids with glass knives on the microtome or on a trimming apparatus. The sides and the face should be clean, and under illumination they should be clear and transparent. Trim the sides of the pyramid at an angle of 28-30 degrees from the face.

The Lowicryl resins are highly crosslinked methacrylates. When they are of the correct hardness they are easily sectioned with either glass or diamond knives.

K4M and K11M are hydrophilic resins. Therefore, as with other polar (water-miscible) resins, precautions should be taken to insure that the block face does not become wet during sectioning. This is best accomplished by sectioning with a level of fluid in the trough which is slightly below normal. In such a situation, the reflection from the trough fluid along the knife edge will be slightly darker than the normal bright silver color.

However, do not lower the trough fluid so much that the knife edge becomes dry. This is particularly important with diamond knives, due to the hydrophobic nature of most diamond knife edges. The most suitable procedure with diamond knives is to orient the trimmed block with the knife edge before the trough is filled. The specimen arm of the microtome is placed in its lowermost position, and the trough is overfilled to form a "reverse meniscus" along the knife edge. Leave the knife in this position for 10-15 minutes.

Immediately before sectioning, lower the level of the trough fluid to produce a dark silver reflection along the knife edge. Make the final advance of the knife and /or block, and commence sectioning.

Since K4M and K11M are hydrophilic resins, the sections should be collected as soon as possible after they are cut.

Sectioning speeds of 2-5 mm/sec are recommended.

Further details on sectioning are given in Lowicryl Letters No. 2.

7. Staining of Sections:

HM20 sections of completely unstained (aldehyde fixed) material give sharp images in the scanning transmission electron microscope (STEM) in the Z-contrast mode. In conventional transmission microscopy, however, the surface relief on the sections contributes to a low contrast and a lack of resolution (7). Therefore, for conventional imaging the sections must be stained.

Due to the hydrophilic and hydrophobic properties of the resins, there are significant differences in the staining behavior of the resins. Also, the amount of staining and contrast which is required is to a great extent dependent upon the investigator, the techniques of staining, and the applications for which the resins are used. Therefore, only general guidelines are given here.

Sections may be stained with either saturated aqueous or alcoholic solutions of uranyl acetate.

Both Reynolds' lead citrate (18) and Millonig's lead acetate (15) give good results.

A series of experiments (w. Villinger, unpublished data) has shown that a particularly useful combination is a first staining with saturated aqueous uranyl acetate, followed by lead acetate according to Millonig's (15) second method:

Staining at Room Temperature :	HM20 HM23	K4M K11M
1. Uranyl acetate, saturated aqueous solution	35 min.	5-10 min.
2. Millonig's lead acetate .	1-3 min	1-3 min.

As with all staining procedures wash well between the uranyl and lead stains, and take precautions, against carbon dioxide during the lead staining and the rinsing after the stain. This is particularly important for lead acetate staining.

³ Since K4M and K11M are hydrophilic, the sections should be incubated on drops of the stains for short periods of time. Prolonged staining may cause distortions and contamination of the sections.

8. Cytochemical and Immunocytochemical Labelling with K4M:

K4M has been used with success in cytochemical and immunocytochemical studies, most notably in conjunction with colloidal gold particles as an electron-opaque marker.

Significant improvements in structural preservation and in lower background labeling (21) are found with K4M.

Colloidal gold particles may be coated with protein A (20).

Sections of K4M - embedded material are first incubated with a specific antibody, and this is followed by an incubation with the protein A-gold complex. The gold particles localize in the antibodies from the first incubation, since protein A binds specifically to the region of IgG.

A technique has also been described in which colloidal gold is coated with enzymes, and the substrate is localized by an incubation of thin sections on the enzyme-gold complex. Colloidal gold has also been directly coated with antibodies, tetanus and cholera toxins, and lectins. For details of these procedures, consult references (5-7, 11, 13, 19-22).

9. References:

1. Acetarin, J.-d. and Carlemalm, E. (1982) The chemical polymerization of Lowicryls. In: Lowicryl Letters No. 1 Chemische Werke Lowi GmbH, Postfach, D-8264 Waldraiburg, Federal Republic of Germany.
2. Acetrarin, J.-D., Carlemalm, E. And Villinger, W. (1986) Developments of new Lowicryl resins for embedding biological specimens at even lowr temperatures. J. Microsc. (In press).
3. Armbruster, B.L., Carlemalm, E., Chiovetti, R., Garvito, R.M., Hobot, J.A., Kellenberger, E. And Villinger, W. (1982) Specimen preparation for electron microscopy using low temperature embedding resins. J. Microsc. 126, 77-85.
4. Ashford, A. Et al. (1986) in press.
5. Bendayan, M. (1981) Ultrastructural localization of nicleic acids by the use of enzyme-gold complexes. J. Histochem. Cytochem. 29, 531-541.
6. Bendayan, M. And Orstravic, T.B. (1982) Immunochemical localization of kollikrein in the rat exocrine pancreas. J. Histochem. Cytochem. 30, 58-66.
7. Bendayan, M. And Shore, G.G. (1982) Immunocytochemical localization of mitochondrial proteins in rat hepatocyte. J. Histochem. Cytochem. 30, 139-147.
8. Carlemalm, E., Garvito, R.M. and Villinger, W. (1982) Resin development for electron microscopy and an analysis of embedding at low temperature. J. Microsc. 126 123-143.

9. Carlemalm, E. Villinger, W., Hobot, J.A., Acetarin, J.D. and Kellenberger, E. (1985) Low temperature embedding with Lowicryl resins: two new formulations and some applications. *J Microscopy* 140, 55-63.
10. Carlemalm, E. And Kellenberger, E. (1982) The reproducible observation of unstained embedded cellular material in thin sections: visualization of an integral membrane protein by a new mode of imaging for STEM, *EMBO J.* 1, 63-67.
11. De Mey, J, Moermans, M., Guens, G., Nuydens, R. And DeBrabander, M. (1981) High resolution light and electron microscopic localization of tubulin with IGS (immuno gold staining) method. *Cellular Bio International Reports* 5, 889-899.
12. Escaig, J. (1982) New instruments which facilitate rapid freezing at 83K and 6K *J. Microsc* 126, 221-229.
13. Horisberger, M (1979) Evaluation of colloidal gold as a cytochemical marker for transmission electron microscopy. *Bio. Cellulaire* 36, 253-258.
14. Kellenberger, E. Carlamalm, E., villinger, W., Roth, J. And Garavito, R.M. (1980). Low denaturation embedding for electron microscopy of thin sections. *Chemische Werke Lowi GmbH, Postfach, D-8264 Waldkraiburg, Federal Republic of Germany.*
15. Millonig, G. (1961). A modified procedure for lead staining of thin sections, *J. Biophysic and Biochem. Cytol.* 11, 736-739.
16. Montesano, R., Roth, J., Robert, A. and Orci, L. (1982) Noncoated membrane invaginations are involved in binding and internalization of cholera and tetanus toxins. *Nature* 296, 651-653.
17. Muller, M. Marti, T. and Kriz, S. (1980) Improved structural preservation by freeze-substitution. In: *Proc. 7th European Congress on Electron Microscopy* 2, 720-721.
18. Reynolds, E.S. (1963) The use of lead citrate at high pH as an electron opaque stain in electron microscopy. *J. Cell biol.* 17, 208-213.
19. Roth, J. (1982a) New approaches for in situ localization of antigens and glycoconjugates on thin sections: the protein A-gold (PAG) technique and the lectin-colloidal gold marker system. *10th International Congress of Electron Microscopy, Hamburg (abstract).*
20. Roth, J. (1982b) The protein A-gold (PAG) technique. Qualitative and quantitative approach for antigen localization on thin sections. In: *Techniques in Immunocytochemistry, Vol. I Academic Press, London* pp104-137.
21. Roth, J., Bendayan, M., Carlemalm, E., Villinger, W. And Garavito, R.M. (1981) Enhancement of structural preservation and immunocytochemical staining in low temperature embedding pancreatic tissue. *J. Histochem. Cytochem.* 29, 663-671.
22. Roth, j., Berger, E.G. (1982) Immunocytochemical localization of galatonyltransferase in HeLa cells: codistribution with thiamine pyrophosphate in trans golgi cisternae. *J. Cell Biol.* 93, 223-229.

References to Immunolabelling:

1. Roth, J. The Colloidal Gold Marker System for Light and Electron Microscopy. Theory and Application. In: "Techniques in Immunocytochemistry" (eds. E.R. Bullock u. P. Petrusz) Academic Press, London vol. II, 1983.
2. Roth, J. Brown, D. And Orci, L. Regional distribution of N-acetyl-D-galactosamine residues in the glomerular podocytes. *J. Cell Biol.* 96, 1189-1196, 1983
3. Roth, J. Application of lectin-gold complexes for electron-microscopic localization of glycoconjugates on thin sections. *J. Histochem. Cytochem.* 31, 987-999, 1983.
4. Roth, J. Application of immunocolloids in light microscopy. Preparation of protein A-silver and protein A-gold complexes and their application for localization of single and multiple antigens in paraffin sections. *J. Histochem. Cytochem.*, 30, 691-696, 1982.
5. Roth, J. Applications of immunocolloids in light microscopy II. Demonstration of lectin-binding sites in paraffin sections by the use of lectin-gold or glycoprotein-gold complexes. *J. Histochem. Cytochem.*, 31, 547-552, 1983.
6. Norman, A.W. Roth, J., and Orci, L., The vitamin D endocrine system: Steroid metabolism, hormone receptors and biological response (calcium binding proteins). *Endocrine Res.* 3, 331-366, 1983.
7. Roth, J., Light and electron microscopic localization of antigenic sites in tissue sections by the protein A-gold technique. *Acta histochem. Suppl.* in press 1983.
8. Roth, J., The preparation of protein A-gold complexes with 3nm and 15 nm gold particles on their use in labelling multiple antigens on ultrathin sections. *Histochem. J.*, 791-801, 1982.
9. Roth, J., Brown, D., Norman, A.W. and Orci, L Localization of vitamin D dependent calcium binding protein in mammalian kidney. *Am. J. Physiology.*, F243 to F252, 1982.
10. Roth, J., Thorens, B. Brown, D., Baetens, D, Garcia-Serguira, L.M., Norman, A.W. and Orci, L., Immunochemical localization of vitamin D-dependent calcium binding protein (CaBP) in duodenum, kidney, brain and pancreas. In: *Vitamin D, Chemical, Biochemical and Clinical Endocrinology of Calcium Metabolism*" (eds. A.W. Norman, K4M. Schaefer, D. V. Herrath and H.-G. Grigoleit) Walter deGruyter & Co., Berlin, New York pp 209-214, 1982.
11. Thorens, B., Roth, J., Norman A.W. Perrelet, A., and Orci, L. Immunocytochemical localization of the vitamin D-dependent calcium binding protein in chick duodenum. *J. Cell Biol.* 94, 115-122, 1982.
12. Roth, J., and Binder M., Colloidal gold, ferritin and peroxidase as markers on electron microscopic double labelling lectin techniques. *J. of Histochem and cytochem.* 26, 163-169. (1978).
13. Roth, J., Bendayan, M., and Orci, L., Ultrastructural localization of intracellular antigens by the use of protein A-gold complex. *J. Histochem. Cytochem.*, 26, 1974-1981 (1978).
14. Paiement, J., and Bendayan, M. Localization of RNA in incubated rat liver nuclei. *J. Ultrastruc. Res.*, 81, 145-157 (1982).